

DVF Series

High efficiency range of filters that filter down to sub 1.0 micron to produce a supply of clean water that is free of solids and has a reduced bacterial count



flow rates

up to 68 m³/h

filtration performance

0.45-10 micron*

Inlet/outlet diameters

up to 3"

minimum operating pressure

1 bar (15 psi)

features:

- All stainless steel vessel material construction
Special alloys upon request
- Giving High Performance filtration through a combination of unique design and specially formulated media
- Filtration of process water with efficiencies of up to 99%
- Filtration of up to 5 times more water as a conventional filter achieving only 20 micron filtration
- Ensuring very short backwash times
- Cleaning up already contaminated systems and achieving improved performance
- Reducing backwash loss of process water by up to 95%
- The requirement of only 1 bar inlet pressure to operate
- Design and technology allows for high flow rates and high performance of filtration
- Applications: Municipal Water, Industrial Water, Irrigation, Oil & Gas and closed loop heating systems

* Media bed construction dependent

How DVF Filters Work

General

The Amiad DVF Automatic Filter is an extremely simple but highly effective technology that brings a more effective way of water filtration than has previously been available. The DVF series is a range of 6 filters that can handle flow rates from 0.74m³/h up to 68m³/h in the larger DVF1200 vessel.

The Filtering Process

Untreated water enters via the inlet which is located at the top of the vessel and is passed through the patented DVF vortex generator. This pipe has a dual outlet configuration inside the vessel which generates a double vortex. This allows for the solids to be suspended above the filter bed. This leaves the water being cleaned free to pass through the specially constructed media bed with less resistance whilst giving the filter bed longer life before backwashing is needed. The filter bed is constructed of 4 different grades of Active Glass media of which the coarse layer is used at the bottom, followed by 2 additional layers of support media and the special blend top layer. The cleaning process is achieved by backwashing the media.

The Self-Cleaning Process

Backwashing the filter bed is achieved by either a set time or, if backwashing is needed sooner, a pressure differential gauge which senses the Delta P when it reaches the pre-set value. Once this has been triggered either by time or pressure differential, then the self-cleaning process begins. The inlet valve shuts followed by the process water out valve. The backwash valve then opens followed by the drain valve. This forces the water being used for backwashing up through the nozzles at the bottom of the vessel, through the filter bed which lifts the solids from the top layer of the media. Once lifted off the bed it is discharged through the drain which is located at the top of the vessel. When the backwash is finished at a pre-determined time, the valves shut in reverse and filter process is resumed.

The Control System

The Amiad AC controller which is used with the DVF Series allows for the backwash timings to be altered to suit the specific site requirements. It also allows for pumps to be added to the system to aid with process and/or backwash flow. There is also a manual backwash facility which will work in conjunction with the set time and differential pressure settings for the filters.

The self-cleaning cycle is initiated as a result of any of the followings:

- Receiving a signal from the pressure differential gauge
- Time interval parameter set at the controller
- Manual start
- Remote access

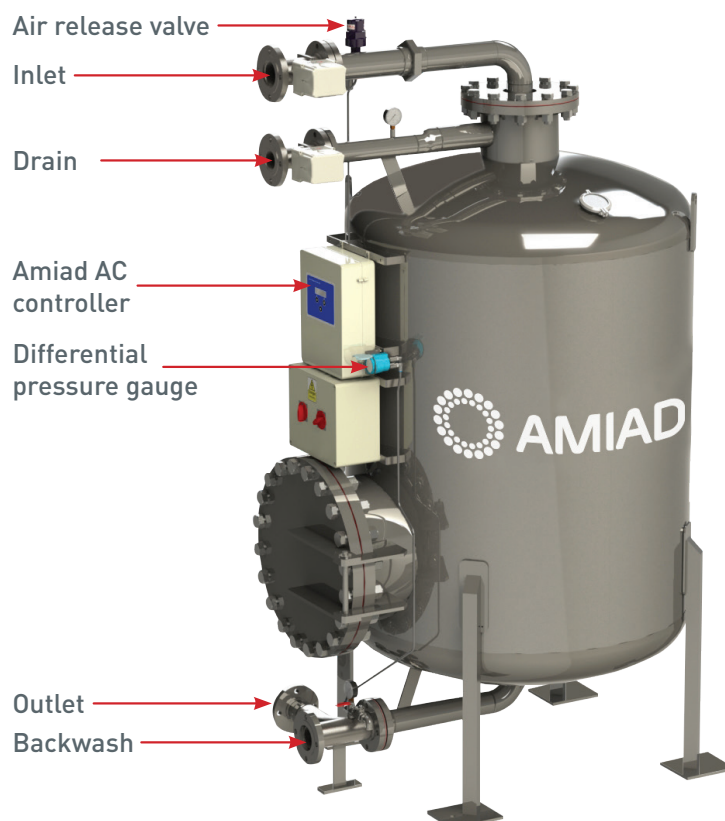

DVF 125/200/300/600/900/1200

Technical Specifications

Filter Type	DVF 125	DVF 200	DVF 300	DVF 600	DVF 900	DVF 1200
-------------	---------	---------	---------	---------	---------	----------

General Data						
Maximum flow rate*	0.75 m ³ /h	2 m ³ /h	4.3 m ³ /h	17 m ³ /h	40 m ³ /h	68 m ³ /h
Inlet/outlet diameter**	½" inlet ½" outlet	1" inlet 1" outlet	1" inlet 1" outlet	1 ½" inlet 1 ½" outlet	2" inlet 2" outlet	3" inlet 3" outlet
Design pressure maximum	5 barg	7 barg				
Minimum working pressure	1 bar					
Maximum allowed DP	1.5 bar					
Maximum temperature***	65 degrees					
Shipping weight (approx.)****	90 kg	280 kg	387 kg	875 kg	2155 kg	3800 kg

* Consult Amiad for optimum flow depending on filtration degree & water quality.

** Flange standards as per request.

*** High temperature option available.

**** Standard shipping weight, not export shipping weight.

Backwash Data						
Backwash flow at 2 bar	0.3 m ³ /h	0.79 m ³ /h	1.77 m ³ /h	7.07 m ³ /h	16 m ³ /h	28 m ³ /h
Backwash time	2 – 4 mins adjustable					
Backwash water volume	10 l based on a 2 min cycle	26 l based on a 2 min cycle	59 l based on a 2 min cycle	240 l based on a 2 min cycle	530 l based on a 2 min cycle	940 l based on a 2 min cycle
Rated operation voltage*	110v or 240v/1/50hz					

* Auxiliary panel will be needed for 3 phase option.

Construction materials	
Filter housing and lid*	SS 304 Built according to PED 5500:2006 Category 3 Other options available upon request
Nozzles*	Polypropylene for use below 60 degrees Other options available upon request for higher temperature applications
Gaskets*	Synthetic rubber, NBR
Filter media	4 varying layers of Activated Glass
Filter base*	Galvanised steel
Pipework*	Standard PVCu, copper or stainless steel

* Other construction materials and coatings for corrosive use or for drinking water are available upon request.

DVF 125/200/300/600/900/1200

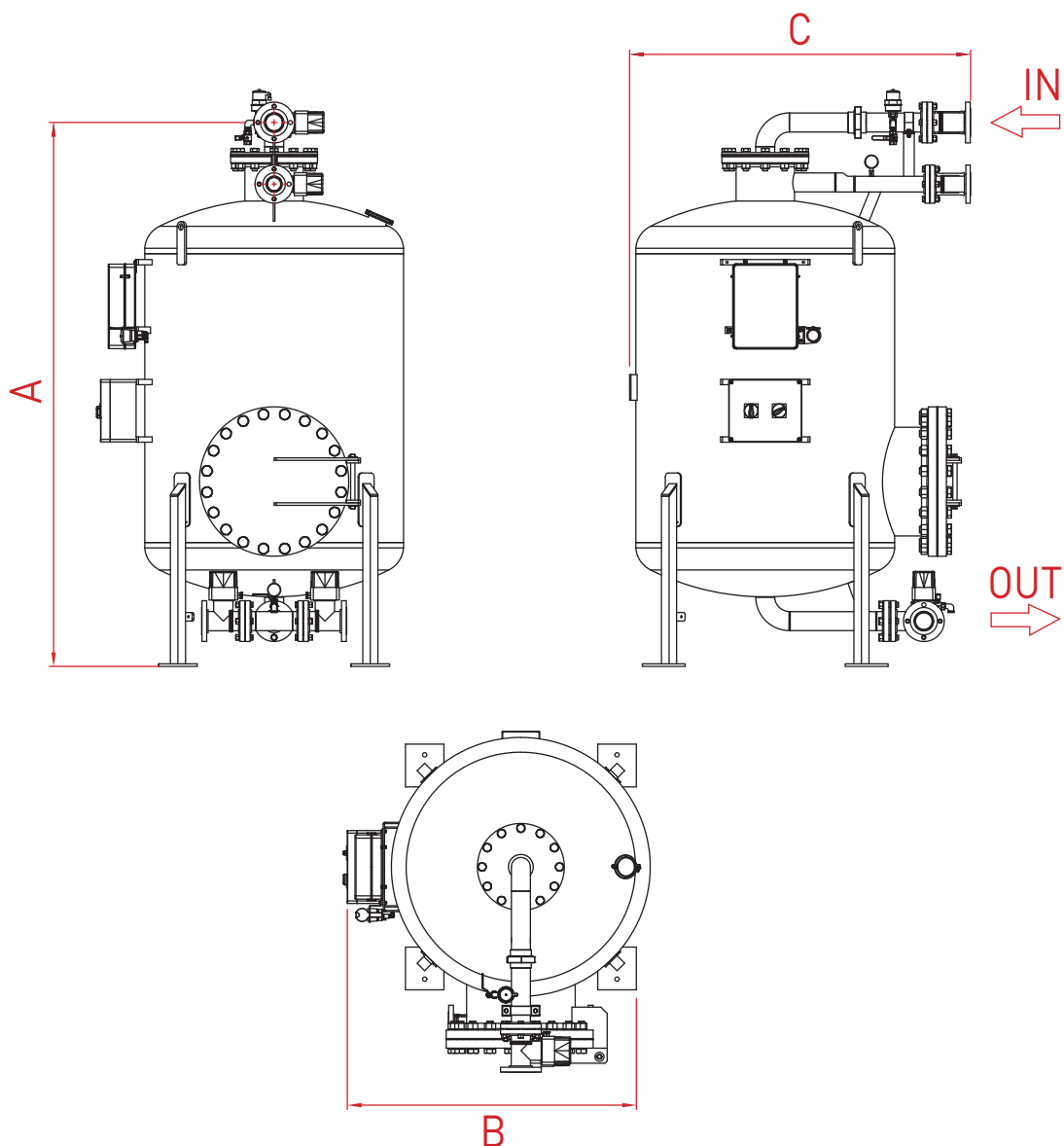

Approximate dimensions request GA for design

Dimensions	DVF125	DVF200	DVF300	DVF600	DVF900	DVF1200
A	740 mm	1,125 mm	1,750 mm	2,161 mm	2,313 mm	2,542 mm
B	418 mm	423 mm	427 mm	648 mm	860 mm	1,375 mm
C	445 mm	533 mm	617 mm	886 mm	1,334 mm	1,593 mm

Weight	DVF125	DVF200	DVF300	DVF600	DVF900	DVF1200
Vessel Empty	63.4 kg	162 kg	162 kg	295 kg	524 kg	815 kg
Media	3.8 kg	30.5 kg	87 kg	257 kg	800 kg	1,465 kg
Water	2.8 kg	27 kg	78 kg	224 kg	729 kg	1,420 kg
Total weight	70 kg	220 kg	327 kg	776 kg	2,053 kg	3,700 kg

Headquarters

Amiad Water Systems Ltd. D.N. Galil Elyon 1, 1233500, Israel,
Tel: 972 4 690 9500, Fax: 972 4 814 1159,
E-mail: info@amiad.com

The Americas



Amiad USA Inc. Main Office and Manufacturing: 120-J Talbert Road, Mooresville, NC 28117,
Tel: 1 704 662 3133, Fax: 1 704 662 3155, Toll Free: 1 800 24 FILTER,
E-mail: infousa@amiad.com www.amiadusa.com

West Coast Sales Office and Warehouse:
1251 Maulhardt Ave, Oxnard, CA 93030
Tel: 805 988 3323, Fax: 805 988 3313, Toll Free: 1 800 969 4055

Brazil

Amiad Sistemas de Água Ltda., Av. Funchal, 411, Conj. 42, Vila Olimpia, São Paulo, CEP 04551-060
Tel: +55 11 31923824, E-mail: infobrasil@amiad.com
Amiad Oil & Gas, E-mail: amisur@adinet.com.uy

Mexico

Amiad Mexico SA DE CV, Vialidad de la Barranca # 6 Piso 4,
Col. Valle de las Palmas 52787. Huixquilucan (Interlomas), Edo de Mexicoo,
Tel/Fax: +52 55 636 28122, E-mail: info@amiadmexico.com

Asia



India

Amiad Filtration India Pvt Limited, 305 Sai Commercial Building,
Govandi St Rd, Govandi Mumbai 400 088,
Tel: 91 22-67997813/14, Fax: 91 22-67997814, Email: info@amiadindia.com

China

Amiad China (Yixing Taixing Environtec Co., Ltd.) 70 Baihe Chang, Xingjie Yixing Jiangsu, 214204,
Tel: 86 510 87134000, Fax: 86 510 87134999, E-mail: marketing@taixing.cc

South-East Asia

Filtration & Control Systems Pte. Ltd., 22 Sin Ming Lane #07-71 Midview City, Singapore 573969,
Tel: 65 6 337 6698, Fax: 65 6 337 8180, E-mail: amiad@amiad.com.sg

Turkey

FTS – Filtration & Treatment Systems, Istanbul yolu 26 Km, Yurt Orta Sanayii, Saray, Ankara,
Tel: 90 312 8155266/7, Fax: 90 312 8155248, E-mail: info@fts-filtration.com

Australia



Amiad Australia Pty Ltd. 138 Northcorp Boulevard, Broadmeadows, Victoria 3047,
Tel: 61 3 93585800, Fax: 61 3 93585888, E-mail: infoau@amiad.com

Europe



Amiad Water Systems Europe SAS, Ilot No4 ZI La Boitardière, 37530 Chargé, France,
Tel: 33 (0) 2 47 23 01 10, Fax: 33 (0) 2 47 23 80 67, E-mail: industry-europe@amiad.com

Amiad Water Systems Europe SAS (Irrigation Division)

100 avenue de l'Anguillon, Z.I. des Iscles, 13160 Chateaufort,
Tel: +33 (0) 4 32 60 10 01, Fax +33 (0) 4 32 60 60 85

Germany

Amiad Water Systems SAS Europe (German branch office)
Zweigniederlassung Deutschland Prinz-Regent-Str. 68 a 44795 Bochum,
Tel: 49 (0) 234 588082-0, Fax: 49 (0) 234 588082-10, E-mail: info@amiad.de

United Kingdom

Amiad Water Systems UK Limited, Compass Business Centre, Unit 6, Lion Way,
Swansea Enterprise Park, Swansea SA7 9FB
Tel: +44 (0)1792 277290, Fax: +44 (0)1792 797707, E-mail: info-uk@amiad.com

